

Date :
Événement :
Pilote :

Moteur :
Embrayage :
Échappement :
Différentiel :
Carrosserie :

Piste :
Aspect :
Grip :
Conditions :
T° Air :
T° Piste :
Pneus AV :
Pneus AR :

TRAIN AR

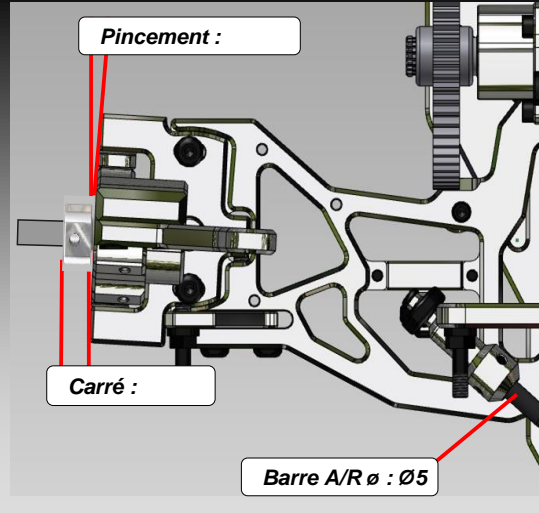
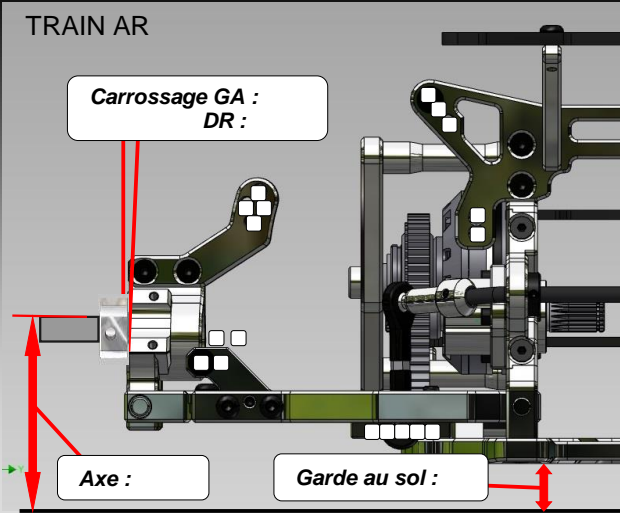

Arrière



Ressort:

Huile :

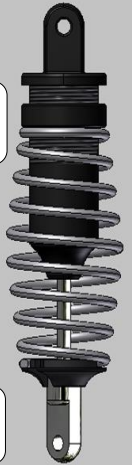

TRAIN AV

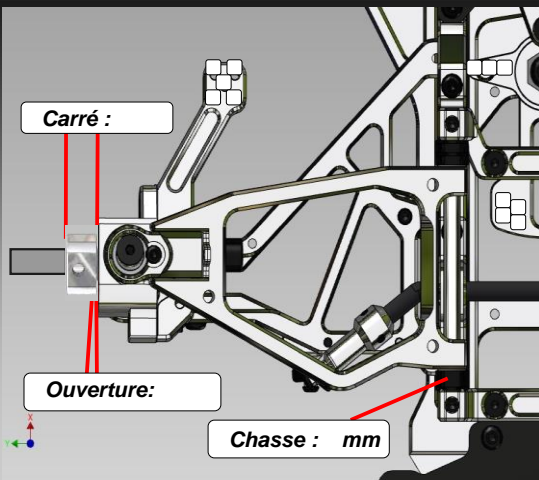
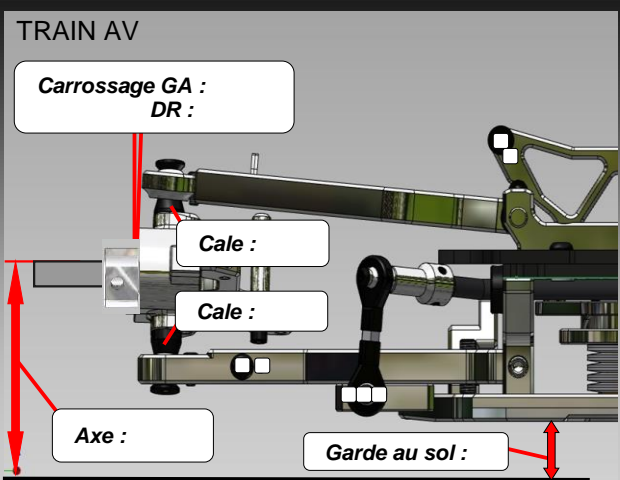

Avant



Ressort:

Huile :

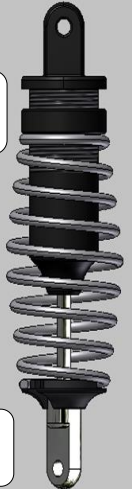

TRANSMISSION

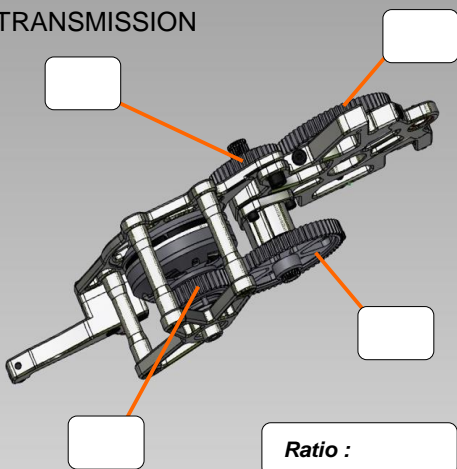

RATIOS

7	24	63	31	6,10
2				
7	24	63	32	5,91
2				
7	25	63	31	5,85
2				
7	24	63	33	5,73
2				
7	25	63	32	5,67
2				
7	24	63	34	5,56
2				
7	25	63	33	5,50
2				

Ressorts AR

JAUNE - ø2.5 / 8

GRIS - ø2.6 / 8

VERT F - ø2.65 / 8

NOIR - ø2.7 / 9

BLEU - ø2.7 / 8.5

VERT - ø2.7 / 8

+ ORANGE - ø2.75 / 8

Ressorts AV

- OR - ø2.8 / 8

ROUGE - ø2.9 / 8

BLANC - ø3.0 / 8

+ ROSE - ø3.2 / 8

NOTES